

REXON DEA

BASIC CHARACTERISTIC



Robust full-height construction, high quality, trouble-free operation and simple mechanism are the qualities that make turnstile **REXON-DEA** to be the most effective solution for applications where maximum security and full automatic identification and access control of people are required. Anti-corrosive surface of all components and high quality final finish of **REXON-DEA** turnstile guarantee long durability and reliable operation not only in indoor environments but also under harsh and extreme conditions of outdoor installations. Modern design, constructive and colour variability make **REXON-DEA** turnstile to be a unique part of access control system. Turnstile **REXON-DEA** is the both-way turnstile with electronic access control, by its rotation 120° ensures the comfortable, easy and safe access to one person. Modern control electronics enables easy setting of its turnstile operating mode and at the same time it ensures the communication with different types of identification and signalling devices.

Turnstile REXON-DEA is offered with the following types of power unit:

Motor drive unit MT (standard)

This turnstile REXON-DEA motorized version is characteristic by its high comfort, reliable and service-free running:

- effective blocking system in combination with motor-driven unit
- automatically adapts the rotation speed of passing persons
- high level of security is provided by prompt turnstile movement stopping at the moment of obstruction detection
- silent and fluent running
- the possibility to set smooth final phase of rotation.

Motor drive unit is supplied in two variants:

- 1) **FAIL-LOCK: turnstile is blocked during the power failure**
- 2) **FAIL-SAFE: the turnstile is unblocked for the free passing during the power failure**

Electromechanical unit TE2

The turnstile is controlled by electromechanical unit with the following functions:

- active blocking system based on electromagnets
- self-centering mechanism to ensure the complete turnstile turning to the basic position
- hydraulic shock absorber for the fluent and silent running
- blocking system prevents the turnstile reverse during passing
- possible unit configuration during the power failure
 - 1) permanently blocked
 - 2) unblocked for free passing

Mechanical unit

This unit has the same characteristics like electromechanical unit with the difference that turnstile running is not controlled by any device. This type of turnstile is applied to regulate and control the number of passing people generally in one-direction.

TURNSTILE MATERIALS AND SURFACE TREATMENT:

Frame of turnstile: steel sheet, thickness 3 mm, surface-finished by powder coating (standard: RAL 9005GS-black)

Covers and roof: steel sheet, thickness 1,5 mm, surface-finished by powder coating (standard: RAL 5010GS-blue)

Top and circumference of the roof: steel sheet, thickness 1,5 mm, surface-finished by powder coating (standard: RAL 9005 GS-black)

Swing barrier: stainless steel (standard: polished)

Wings of barrier: stainless tube $\varnothing 22$ (standard: polished)

Internal block: stainless tube $\varnothing 22$ (standard: RAL 9005GS-black)

Other mechanical parts of turnstile are finished by galvanic zincing or blackening.

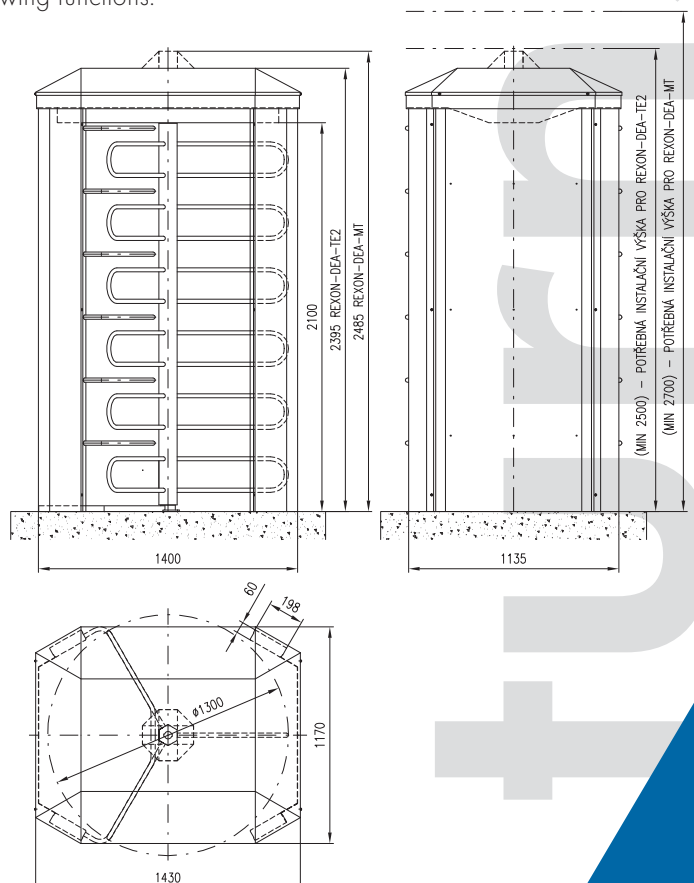

INTERFACE:

Turnstiles are controlled by microprocessor control electronics that communicates with superior control system by the help of the following input and output TTL signals:

- for each passage direction one activation input
- output for signalling situation the turnstile in operation (BUSY)
- two outputs signalling the actual passage through turnstile in existing direction (especially used for ANTIPASSBACK function)

Control electronics of electromechanical power unit is except TTL outputs also equipped with output relays.

When the motor drive unit is used, the control electronics is equipped for each way of direction with input for permanent activation of free passing in existing direction and enables the time setting to realize the passage through turnstile at 6 or 10s (Time-out). Control electronics are equipped with switch-off acoustic position signals the turnstile is running (BUSY). Control electronics is protected against the short-circuit, overloading or mismatch of polarity.

Turnstile operation during power failure

TE2 unit: at setting the Y configuration, the turnstile will be automatically unblocked during power failure and it will freely turn in both directions

FAIL-SAFE unit: turnstile will be automatically unblocked during power failure and it will freely turn in both directions through the transfer mechanism

FAIL-LOCK unit: in using the backup device it is possible to ensure the turnstile standard functions during the time of 6 hours without possibility of automatic unblocking and free turning

Operating modes

By external signal from identification system or remote control panel it is possible to turn round the turnstile 120° and by that way enable the passing to one person. For each way of direction it is possible to define different operating modes:

1. free passage
2. controlled passage
3. permanently blocked

This setting can be realized for any direction eventually for both directions at the same time.

BASIC TECHNICAL PARAMETERS

Tabulka elektrických parametrů pohonných jednotek

Type of drive unit	Rated supply voltage	Power supply at the basic turnstile mode		
		Standby	BUSY	Transit
FAIL-LOCK motor	12VDC	0,8W	10W	20 - 30W
FAIL-SAFE motor	12VDC	1W	1W	15 - 20W
Electromechanical without power blocked	24VAC/DC	2,5W	8W	8W
Electromechanical without power released	24VAC/DC	12W	8W	8W

- standard range of working temperatures +10° ... +50° C
- range of working temperature with heating module: -25° ... +50° C
- range of storage temperatures: 0° +50° C
- maximum relative humidity 80% (non-aggressive environment)
- MCBF: 3.000.000 cycles (number of cycles before error)



The number of passages, depending on type of control electronics, operating mode and the way of identification of passing people, is between 15 to 30 persons per minute.

Increase of power supply on motor drive unit with automatic warming is 24W. The power supply can be also increased by using the accessories.

ACCESSORIES

Holders for accessories:

Holders for placing the readers of identification systems or other accessories (for example: TrafficLight information panel).

Lighting:

Lighting of turnstile interior

Anchoring frame:

Steel frame to fix the turnstile, for example through the interlocking pavement.

TrafficLight information panel:

- information about the turnstile trafficability in set direction
- information about transit permission based on evaluation of identification system

Touch control panel:

- turnstile manual control
- turnstile manual unblocking

Back-up accumulator:

During a power failure the accumulator ensures its continuous operation for a period of minimally 6 hours.

Counter:

Turnstile can be equipped with the passage counter.

Identification systems:

For verification of access right of passing persons it is possible to connect to these turnstiles REXON - DEA any type of barcode, magnetic card, proximity card, smartcard, biometric reader etc.

Specific variants:

- stainless steel design
- custom colour in spray according to RAL