

EASYGATE



Easygate represents the new way in entrance control system, trend that requires maximum comfort for users but at the same time maximum security. Aesthetic design combining glass with stainless steel makes the outlook very attractive and unique. Sophisticated state-of-the-art electronics offers wide range of operation modes, large throughput capacity and high level of personal safety.

Easygate typical installations are in banking, finance, business, government but they become more and more popular also in transit system, leisure etc.

DRIVE UNIT:

FAIL-SAFE MOTOR

MATERIALS:

FRAME: zinc coated steel profiles

TOP LID: 304 grade brushed stainless steel (standard)

- customization:
- wood
 - marble
 - stone ...

WING PANEL: 8 mm tempered safety glass (1200mm, 1800mm)

SIDE PANELS: 304 grade brushed stainless steel

GLASS SLIDE COVER: black powder coated (standard)

304 grade brushed stainless steel (optional)

CONFIGURATION:

SECURITY LEVEL:

medium - 1200mm high glass panels
high - 1800mm high glass panels

PASSAGE WALKWAY:

standard - 550mm
wide - 900mm

FUNCTION:

PASSAGE IN BOTH DIRECTIONS, ELECTRONICALLY CONTROLLED.

An input from an access control or identification system or manual push button will open the gate. Unauthorized access by "tailgating", entering without valid identification card or entering from the opposite direction, activates the built-in alert system.

OPERATION MODES:

NORMALLY OPEN (N/O)

- glass barrier presents in the open position. In the event of unauthorised entry glass barrier closes

NORMALLY CLOSED (N/C)

- glass barrier presents in the closed position. In the event of an authorised entry, glass barrier opens

SAFETY DEVICE:

7 photocells detect unauthorized access or "tailgating" and prevent from personal injury Intelligent electronic sensors detect an obstruction and open the glass barrier.

POWER FAILURE:

in the event of power failure the easygate could be set for different modes

- glass barrier remains in the current position
- glass barrier automatically opens (back-up battery required)
- glass barrier can be manually opened



FIRE ALARM: interface contacts (0 V) are supplied to open gates in the event of an alarm signal being received.

POWER SUPPLY: 12V DC (external power supply required)

POWER CONSUMPTION: standby - 5W / operation - 90W

OPERATING TEMPERATURE RANGE: 0°...+50°C (with heating module)

MAXIMUM RELATIVE HUMIDITY 80% (non-aggressive environment)

PASSAGE THROUGHPUT: max. 30 persons/min (subject of change)

WEIGHT: standard lane - max. 380 kg

ACCESSORIES:

- Traffic light Access panel
- Traffic light Direction panel
- Battery back-up
- Proximity card reader integration inside the cabinet
- Touch Button panel for remote operation mode set-up and remote manual control
- Software for remote monitoring and manual control
- Glass imprint
- Integrated visitor card collector with stock box

Dimensional drawing (in millimeters)

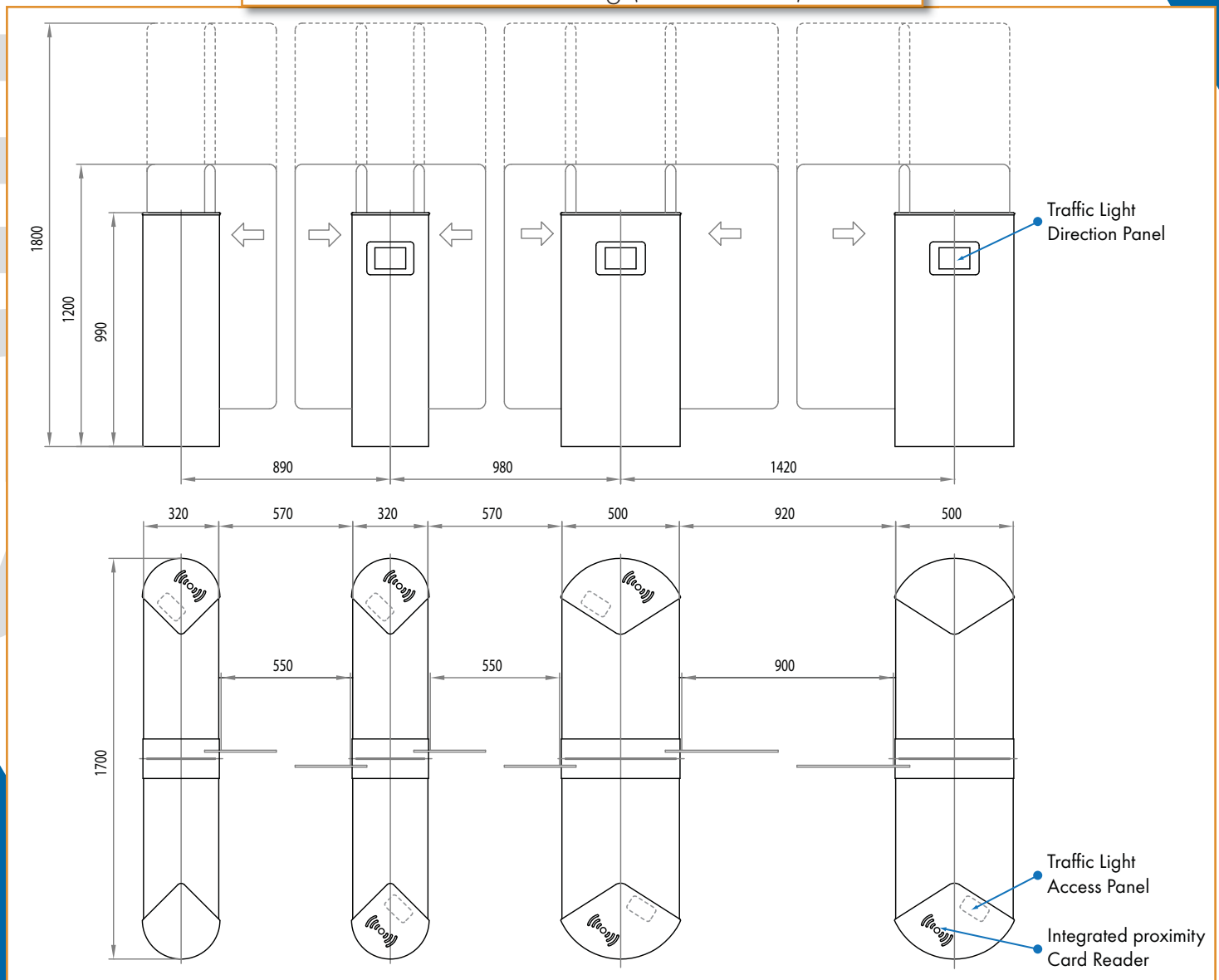



2x standart walkway

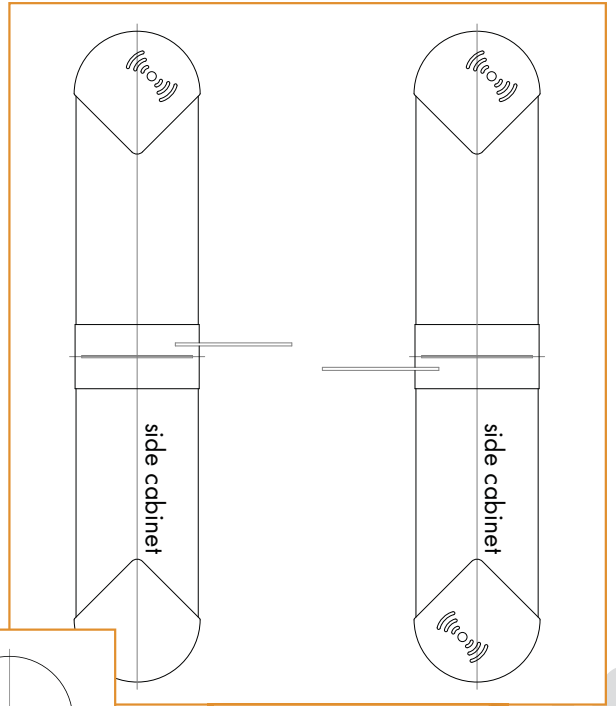

1x standart walkway

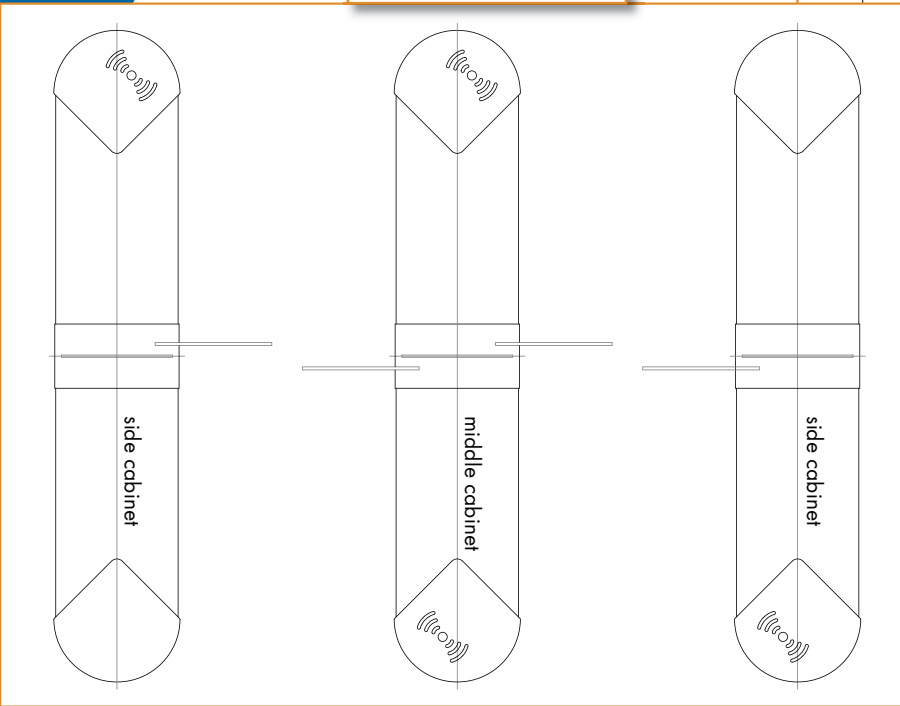

1x standart, 1x wide walkway

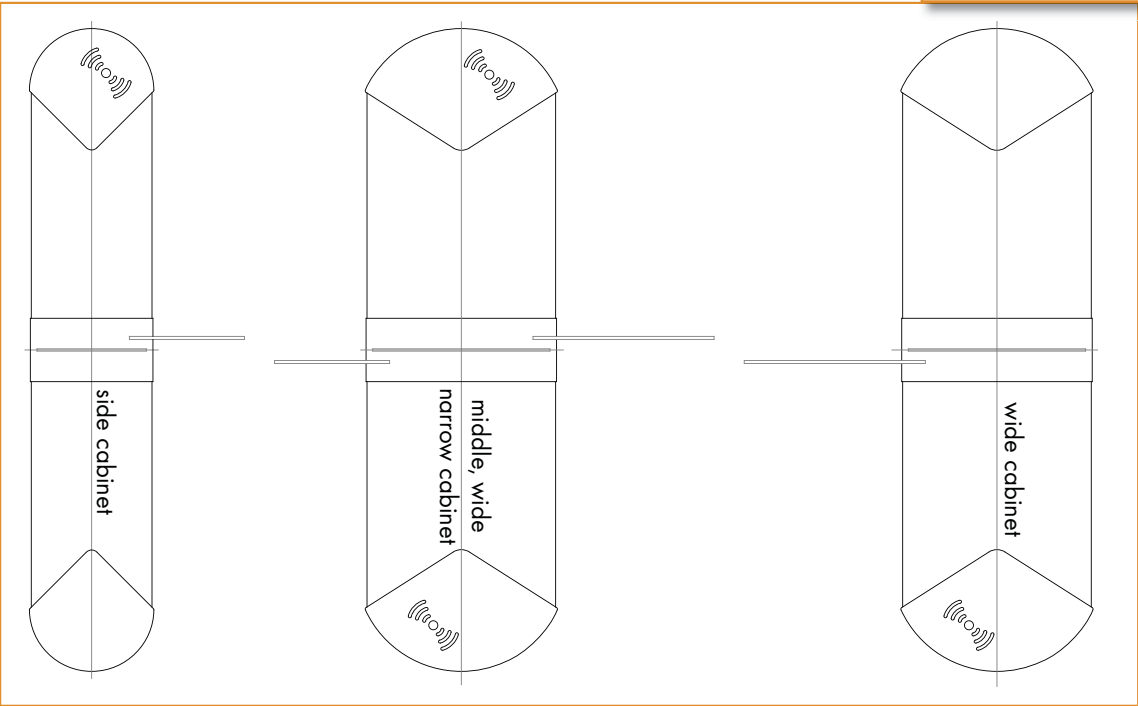

configurations

2x standart, 1x wide walkway with swing gate, 1200mm glass panels

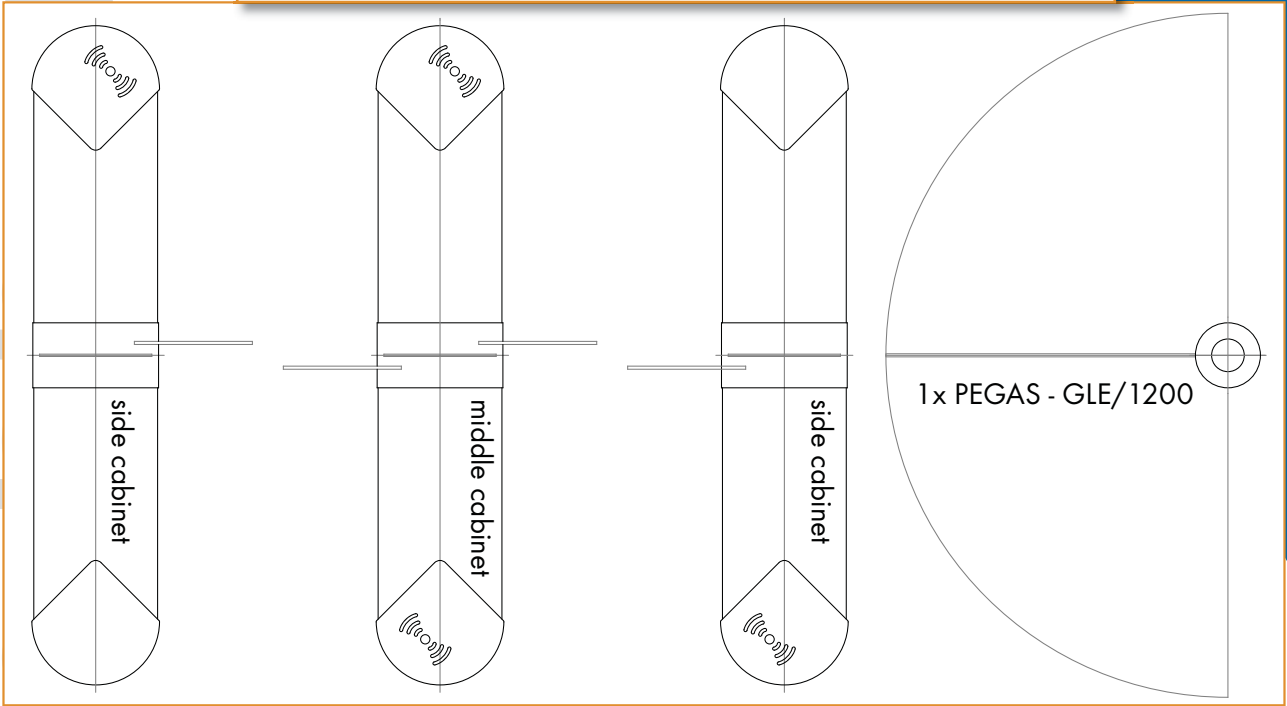

2x standart, 1x wide walkway with swing gate, 1800mm glass panels

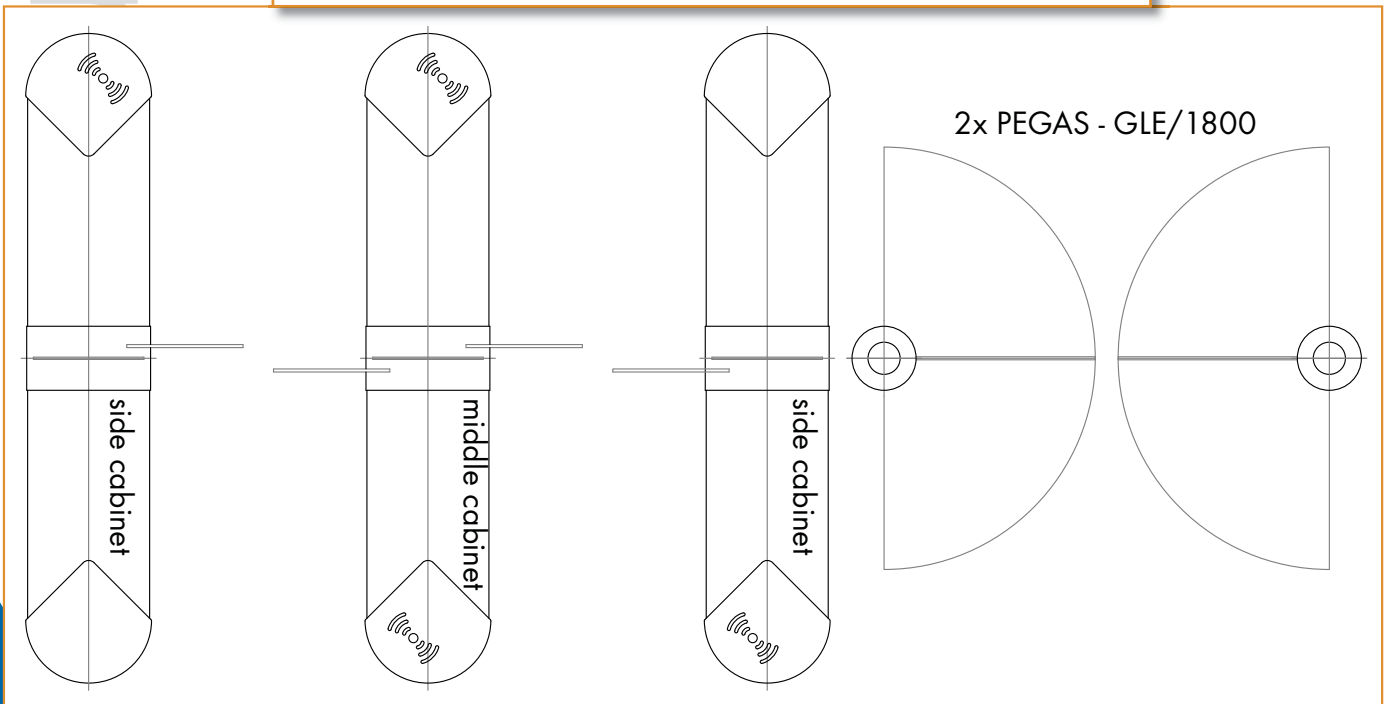

examples
configuration